

## **RAPID-ROLL DOOR PARTS MANUAL**



---

# **MODEL 230**

**975-A OLD NORCROSS ROAD  
LAWRENCEVILLE, GA 30045**

**(770) 338-5000 TEL**

**(770) 338-5034 FAX**

**(877) 925-2468 TOLL FREE**

# **TABLE OF CONTENTS**

MODEL 230 PARTS LIST .....	5
MODEL 230 PARTS LIST .....	7
OVITOR MOTOR & GEARBOX ASSEMBLY .....	11
230 CRANK SWITCH WITH OVITOR MOTOR .....	12
230 BONFIGLIOLI MOTOR REPLACEMENT PARTS ....	13
BONFIGLIOLI MOTOR w/ OVITOR GEARBOX .....	15
BONFIGLIOLI MOTOR & GEAR BOX .....	17
230 SIDE FRAME ASSEMBLY /OLD STYLE .....	21
230 BOTTOM BEAM ASSEMBLY / OLD STYLE.....	23
230 OVITOR ONLY, CHAIN DRIVE ASSEMBLY .....	25
230 TOP ROLL, CSS ASSEMBLY .....	27
230 SIDE FRAME ASSEMBLY / NEW STYLE.....	32
230 NEW STYLE PHOTOCELLS (ADS) .....	33
230 FRONT COVER ASSEMBLY .....	37



**WARNING**

***DO NOT INSTALL, OPERATE, OR SERVICE THIS PRODUCT UNLESS YOU HAVE READ AND UNDERSTAND THE SAFETY PRACTICES, WARNINGS, INSTALLATION, AND MAINTENANCE INSTRUCTIONS CONTAINED IN THIS MANUAL.***

***CUSTOMER SERVICE TOLL FREE 877-925-2468***

***CUSTOMER SERVICE FAX 770-338-5034***

***TO EXPEDITE QUOTES, INCLUDE DOOR SERIAL NUMBER***

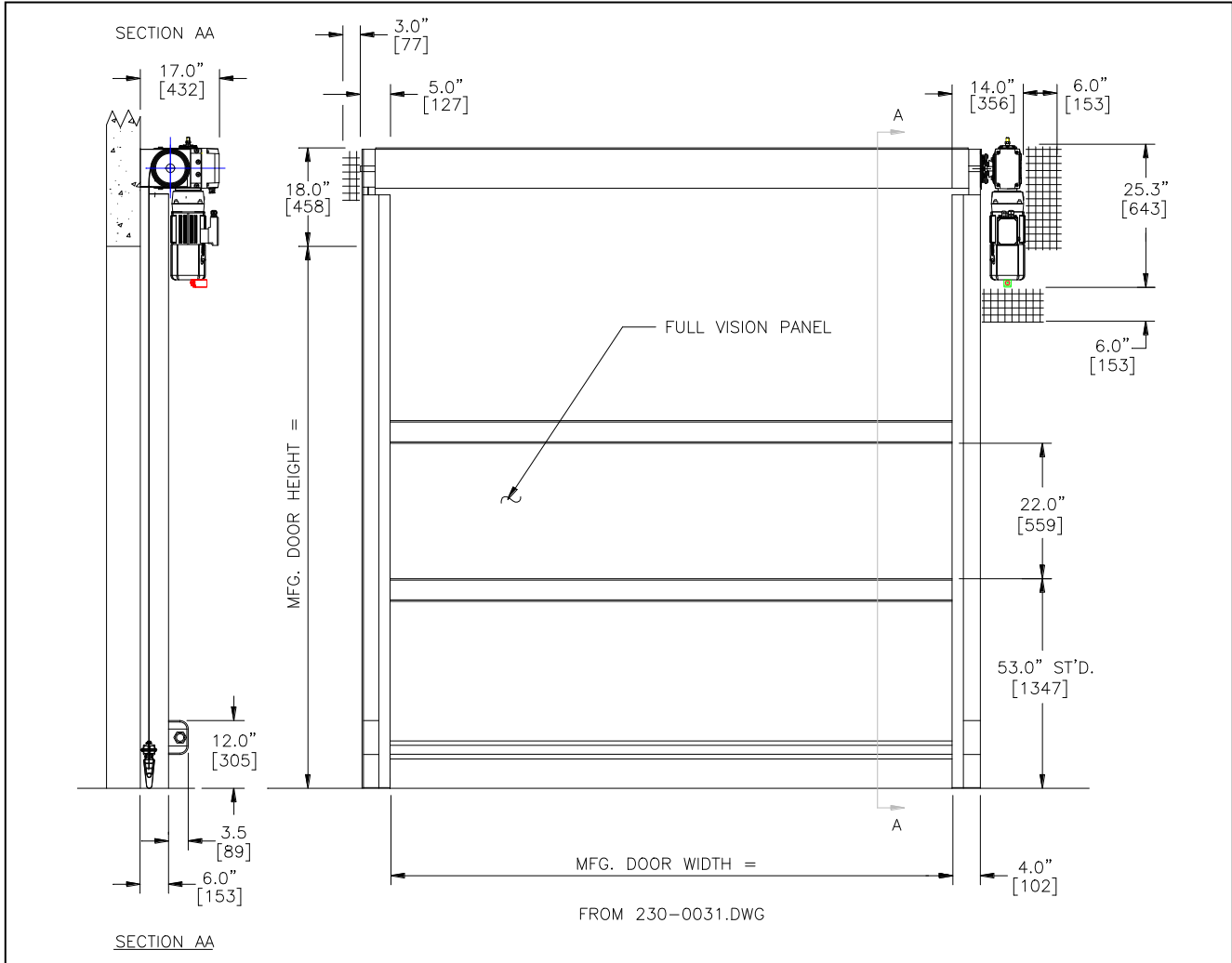

## Basic Approval Drawing, Model 230

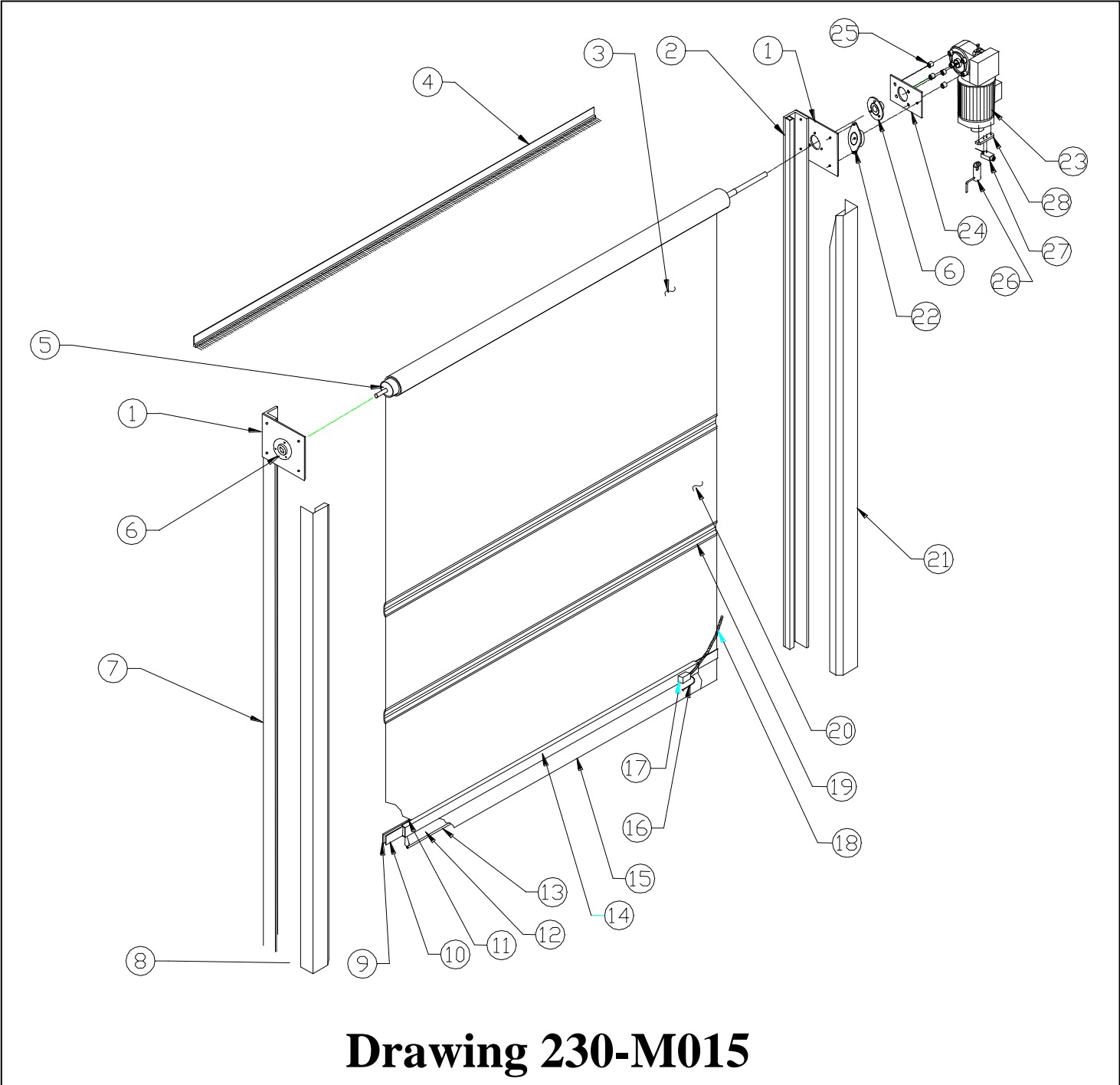

**Drawing 230-M015**

**MODEL 230 PARTS LIST**  
**Refer to Drawing 230-M015 unless Noted**

ITEM	ITEM DESCRIPTION	PART #	QTY	NOTE(S)
1	BEARING PLATE	23-4905-96	2	
2	STEEL TUBE, SIDE FRAME	23-4220-96	2	SEE DWG 230-M035
2	RECTANGULAR TUBING, 1.5 X 1.0 X 16 GA.	23-4220-00	2	SEE DWG 230-M070, NEW REV
3	DOOR FABRIC	**	1	Contact factory w/ door serial #
4	BRUSH SEAL, 3"	17-7611-95	1	
	ALUM RETAINER FOR BRUSH SEAL	17-7614-98	1	PART OF #4 ABOVE
5	COMP DRUM TUBE W/SHAFTS, SZ 8	**	1	SEE DWG 230-M020
6	BEARING W/LOCKING COLLAR	23-4713-96	2	
	BEARING FLANGE	23-4714-96	4	
7	STEEL ANGLE, SIDE FRAME	23-4980-96	2	SEE DWG 230-M035 OR 230-M070
8	COVER, SIDE FRAME	23-4992-96	2	SEE DWG 230-M035, OLD STYLE
	COVER, SIDE FRAME, 156" LG (230 W/HEM)	23-4997-00	2	SEE DWG 230-M065
	COVER, SIDE FRAME, 192" LG (230 W/HEM)	23-4998-00	2	SEE DWG 230-M065
9	PLASTIC END BRACKET GUIDE, UHMW	23-1504-96	2	SEE DWG 230-M040
9	ENDBRACKET, UHMW	23-1505-00	4	SEE DWG 230-M060 (NEW)
10	PLASTIC END BRACKET, UHMW	23-1505-96	2	SEE DWG 230-M040
10	ENDBRACKET, UHMW (ORDER 23-1505-00)			SEE DWG 230-M060 (NEW)
11	FLAT STEEL BAR	23-1500-96	1	SEE DWG 230-M040
12	MESH FABRIC FOR SAFETY EDGE	NO PART #	1	SEE DWG 230-M040
13	RUBBER PROFILE	10-1230-88	1	SEE DWG 230-M040
13	RUBBER PROFILE	705405	1	SEE DWG 230-M060 (NEW)
14	RECTANGULAR STEEL TUBE	23-1501-96	1	SEE DWG 230-M040
15	SAFETY EDGE YELLOW FABRIC	96-1412-00	1	SEE DWG 230-M040

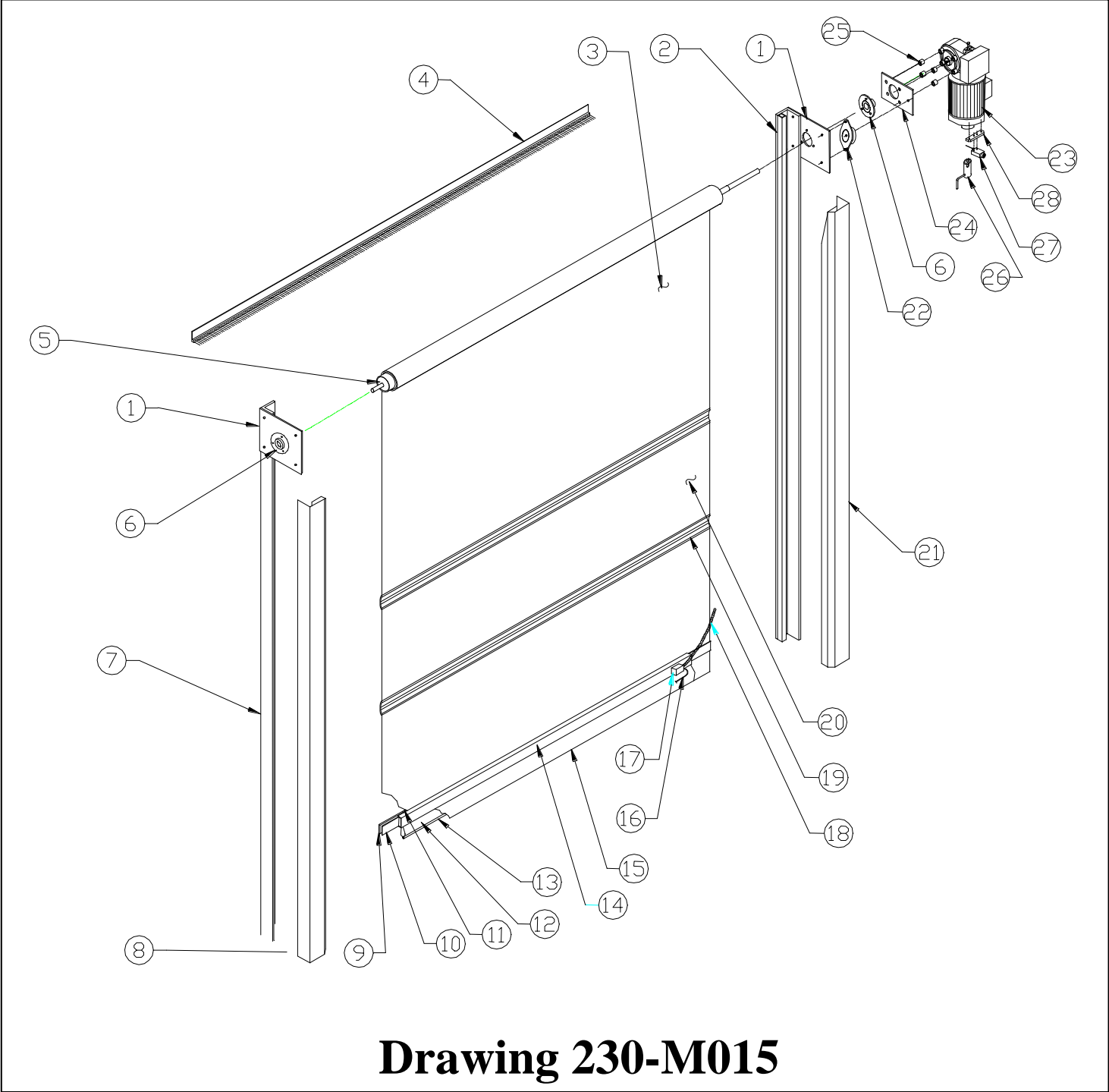

**Drawing 230-M015**

## MODEL 230 PARTS LIST

*Refer to Drawing 230-M015 unless Noted*

ITEM	ITEM DESCRIPTION	PART #	QTY	NOTE(S)
16	PLASTIC TUBE FOR SAFETY EDGE	96-1308-83	2	
17	PRESSURE SWITCH	96-6000-79	1	
18	RETRACTILE CORD	96-6100-83	1	
19	WINDRIB, ALUMINUM	23-5281-00	2	DW + 6"
	WINDRIB, HINGE (NOT SHOWN)	23-5282-00	4	DW + 6"
20	CLEAR PVC FULL VISION PANEL	96-3288-88	1	(W+6") X 24"
	OPTIONAL REINFORCED PANEL		1	Consult Factory for details & availability
21	COVER, SIDE FRAME	23-4992-96	1	SEE DWG 230-M035, OLD STYLE
	COVER, SIDE FRAME, 156" LG (230 W/HEM)	23-4997-00	2	SEE DWG 230-M065
	COVER, SIDE FRAME, 192" LG (230 W/HEM)	23-4998-00	2	SEE DWG 230-M065
22	TORQUE DAMPER, RA100B	96-4830-91	1	
23	SIZE 8 DRIVE UNIT, CONSISTING OF:			
	GEARBOX, TVC8X	6610T0007	1	See drive unit section for clutch parts required
	MOTOR, MJ763, 208-240V ONE SPD	01-7635-90	1	OVITOR
	MOTOR, MJ763, 440-480V ONE SPD	01-7631-90	1	OVITOR
	MOTOR, MJ763, 550-600V ONE SPD	01-7633-90	1	OVITOR
	MOTOR, MDJ762, 208-240V, TWO SPD	01-7625-90	1	OVITOR
	MOTOR, MDJ762, 440-480V, TWO SPD	01-7621-90	1	OVITOR
	MOTOR, MDJ762, 550-600V, TWO SPD	01-7623-90	1	OVITOR
24	GEARBOX MOUNTING PLATE, SIZE 8	23-4910-97	1	OVITOR
25	GEARBOX SPACER, SIZE 8	23-0285-97	4	
26	HAND CRANK FOR "76" SERIES MOTOR	00-9200-01	1	MJ763, MDJ762
27	KILL/CRANK SWITCH ASSY CONSISTS OF:	09-9201-25	0	Replaced by 980062-4000 & 230021-4000 plus hardware
	LIMIT SWITCH BODY + HEAD	980062-4000	1	
	BRACKET	230021-4000	1	
28	LIMIT SWITCH MOUNTING PLATE	00-9203-98	0	Replaced by 980062-4000 & 230021-4000 plus hardware

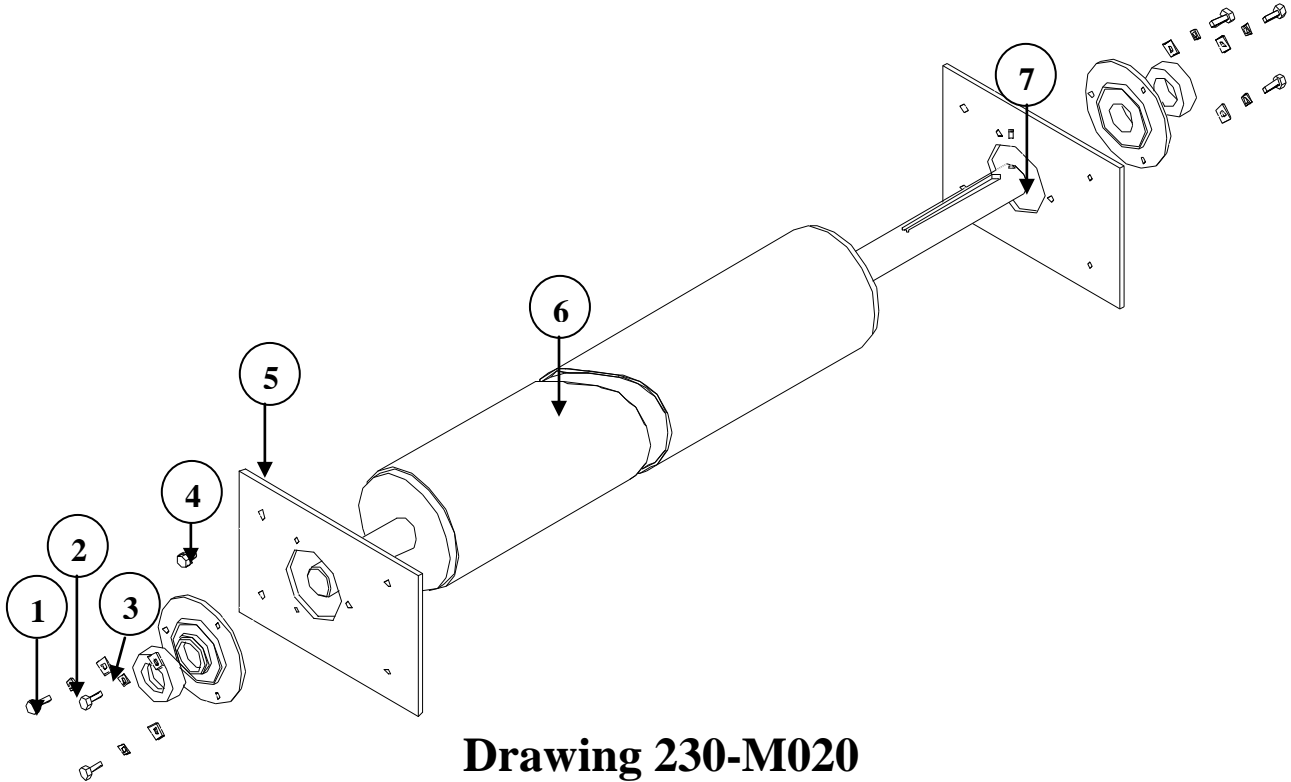

**Drawing 230-M020**

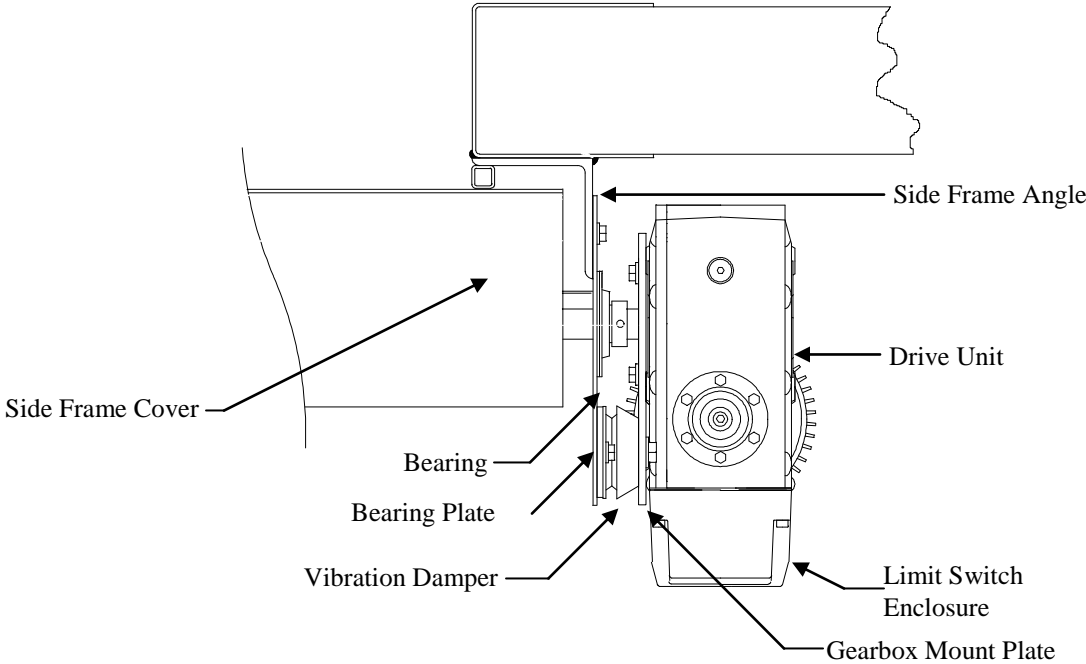

## Drawing 230-M025

### 230 TOP ROLL COMPONENTS

*Refer to Drawing 230-M020 and 230-M025 unless Noted*

ITEM	ITEM DESCRIPTION	PART #	QTY	NOTE(S)
1	BOLT, HEX HEAD 5/16-18 X 3/4"	N/A	6	
2	WASHER, LOCK 5/16"	N/A	6	
3	WASHER, FLAT 5/16"	N/A	6	
4	BOLT, 3/8-16 X 1/2" FLANGE HEX HD	N/A	4	
5	BEARING PLATE, 230	23-4905-96	2	
6	COMPLETE DRUM ROLL ASSY - 230		1	
	DRUM ROLL TUBE	96-3399-99	1	DW + 3.0"
	<u>ENDBOSS/STUBAXLE-230 DRIVE SZ 8 (1-1/4")</u>	<u>23-3610-96</u>	<u>1</u>	<u>SIZE 8 DRIVE (OVITOR)</u>
	BONFIGLIOLI DRIVE Stubaxle 30mm	4521t0166	1	BONFIGLIOLI
	<i>ENDBOSS/STUBAXLE NON DRIVE SIDE</i>	23-3620-96	1	
	ENDBOSS, STUBAXLE CHAINDRIVE	23-3661-97	1	USED WITH CSS ONLY
7	BEARING PLATE, 230	23-4905-96	1	
8	BEARING FLANGE RING	23-4714-96	4	
9	BEARING W/COLLAR 1-3/8	23-4713-96	2	
<b>PARTS NOT SHOWN ON ATTACHED DRAWING: COMPLETE WIDTH GAUGE ASSY - 230, CONSISTING OF:</b>				
	BRUSH SEAL, 3"	17-7611-95	1	DW - 0.5"
	ALUM. RETAINER, 2"	17-7614-98	1	DW - 0.5"

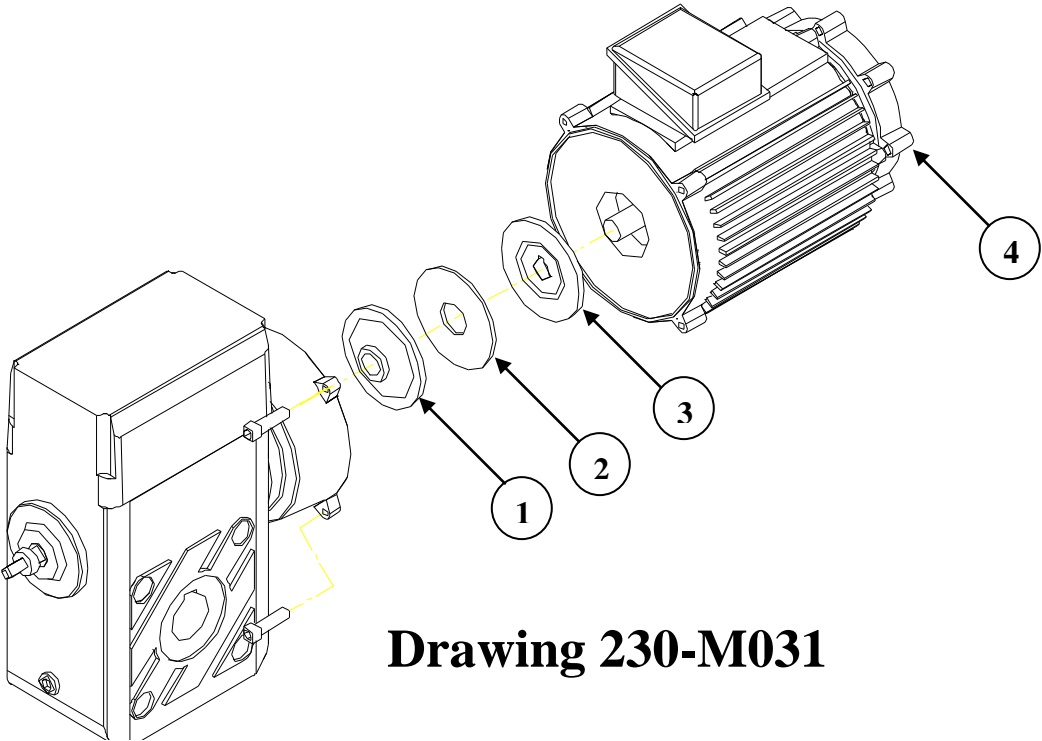
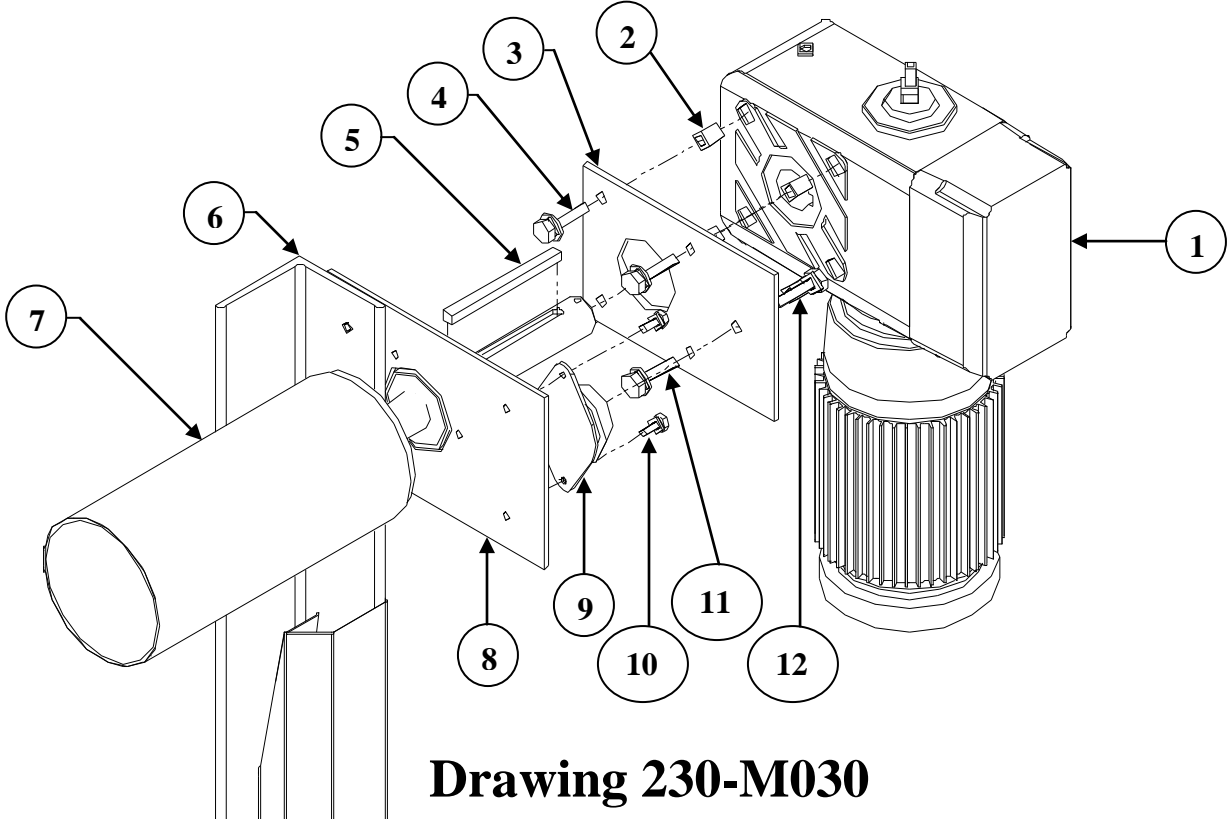



**OVITOR MOTOR & GEARBOX ASSEMBLY**

*Refer to Drawing 230-M030 unless Noted*

ITEM	ITEM DESCRIPTION	PART #	QTY	NOTE(S)
1	GEARBOX, TVRC HOLLOW SHAFT, SZ 8	6610T0007	1	Replaces 00-9080-25
	OVITOR MOTOR		1	See drwg 230-M015
2	SPACER, 3/4" OD X 1/2" ID X 3/4"	23-0285-97	4	
3	GEARBOX MOUNTING PLATE, 230 SZ 8	23-4910-97	1	
4	BOLT, HEX HEAD M12 X 45MM	NPN	4	
5	DRIVE SHAFT KEY	NPN	1	
6	SIDE FRAME ASSY			See drwg 230-M015
7	DRUM TUBE			See drwg 230-M020
8	BEARING PLATE	23-4905-96	2	
9	TORQUE BRACKET VIBRATION DAMPER	96-4830-91	1	
10	BOLT HEX HEAD 5/16-18 X 3/4"	NPN	2	
	FLAT WASHER, LOCK 5/16"	NPN	2	
11	SEE ITEM 4			
12	8.8 HEX HD BOLT, 10MM - 1.5 X 20	NPN	1	
	LOCKWASHER, 10MM	NPN	1	
<b>ADDITIONAL ITEMS SHOWN ON DRAWING 230-M031</b>				
1	CLUTCH PRESSURE PLATE, GB	00-1083-25		
2	FRICITION LINING	00-0481-25		
3	CLUTCH PLATE, MOTOR SIDE	00-0086-25		
	COMPRESSION SPRING	00-0464-25		Not shown
	COMPRESSION BAR	00-2471-25		Not shown
	LIMIT SWITCH SHAFT ASSY	00-2287-25		Not shown
	SEAL KIT FOR TVRC GEARBOX	00-0650-25		Not shown
	BEARING KIT FOR TVRC GEARBOX	00-0651-25		Not shown
4	BRAKE LINING W/COVER	00-0903-25		

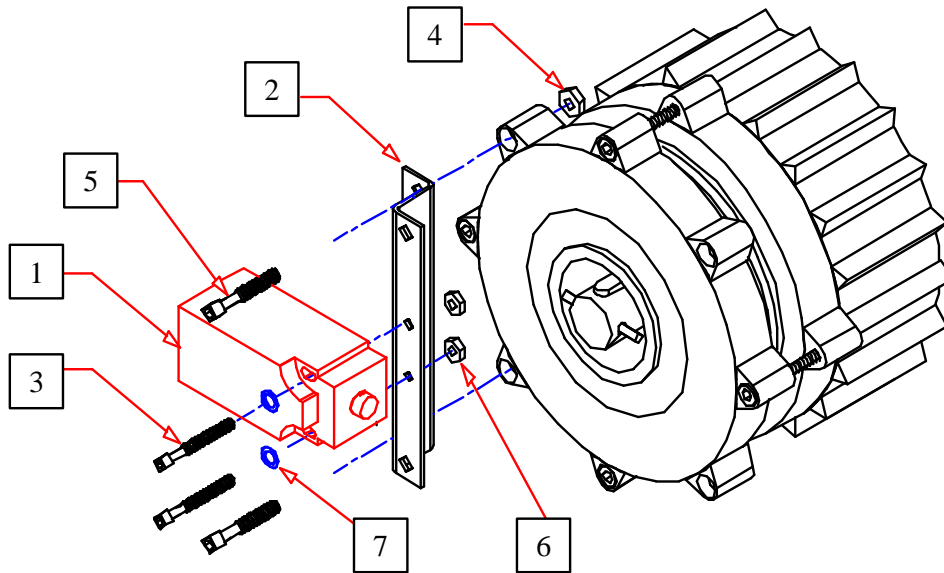

**Drawing 230064-2000M**

***230 CRANK SWITCH WITH OVITOR MOTOR***

*Refer to Drawing 230064-2000M unless Noted*

ITEM	ITEM DESCRIPTION	PART #	QTY	NOTE(S)
1	LIMIT SWITCH, CRANK	980062-4000	1	
2	BRACKET, LIMIT SWITCH MOUNT	230021-4000	1	
3	SCREW, SOCKET HD 8-32 x1-3/8"	NPN	2	
4	NUT, 10-32 NYLOCK	NPN	2	
5	SCREW, SOCKET HD 10-32 x1-3/8"	NPN	2	
6	NUT, 8-32 NYLOCK	NPN	2	
7	WASHER, FLAT #8	NPN	2	

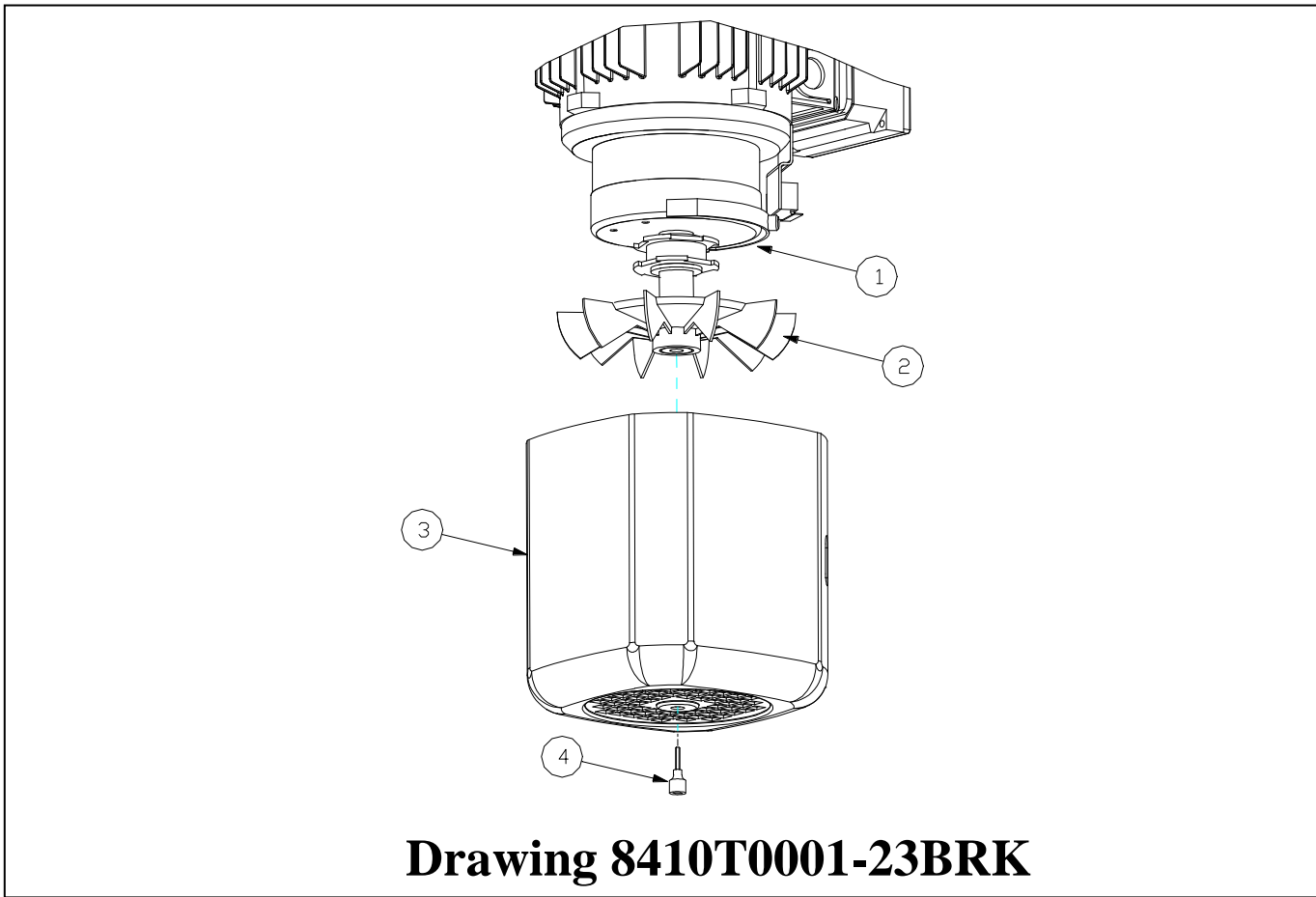

**Drawing 8410T0001-23BRK**

**230 BONFIGLIOLI MOTOR REPLACEMENT PARTS**

*Refer to Drawing 8410T0001 and 230-BFG-MTR unless Noted*

ITEM	ITEM DESCRIPTION	PART #	QTY	NOTE(S)
1	BRAKE, 180VDC, 15NM FOR BONFIGLIOLI	6622T0007	1	For drive w/ Ovitor gearbox only ( AF )
	BRAKE, 180VDC, 15NM FOR BONFIGLIOLI	6622R0018	1	For drive w/ Bonfig gearbox only ( AE )
Not shown	FRICITION DISK, BONFIG BRAKE	6622T0012	1	
Not shown	STATIC PLATE	6622T0013	1	
2	FAN, Large Bonfig motor	6621T0003	1	
3	COVER, FAN, LARGE, BONFIG. MOTOR	6621T0002	1	
4	SOCKET, 6MM Allen, 3/8" DRIVE	4521T0134	1	<b><u>Manual crank</u></b>

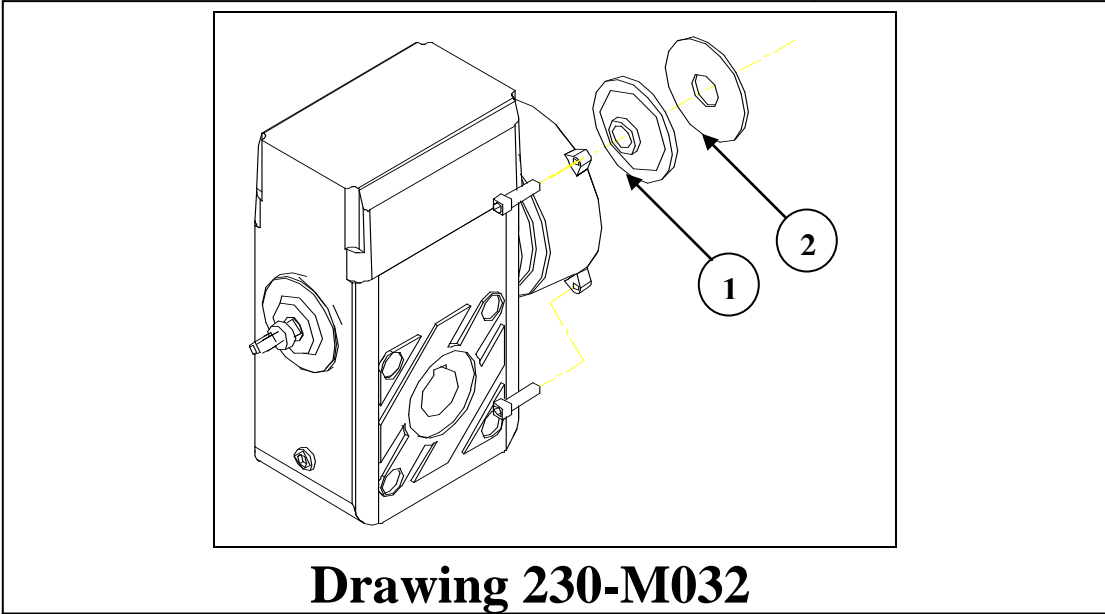

**Drawing 230-M032**

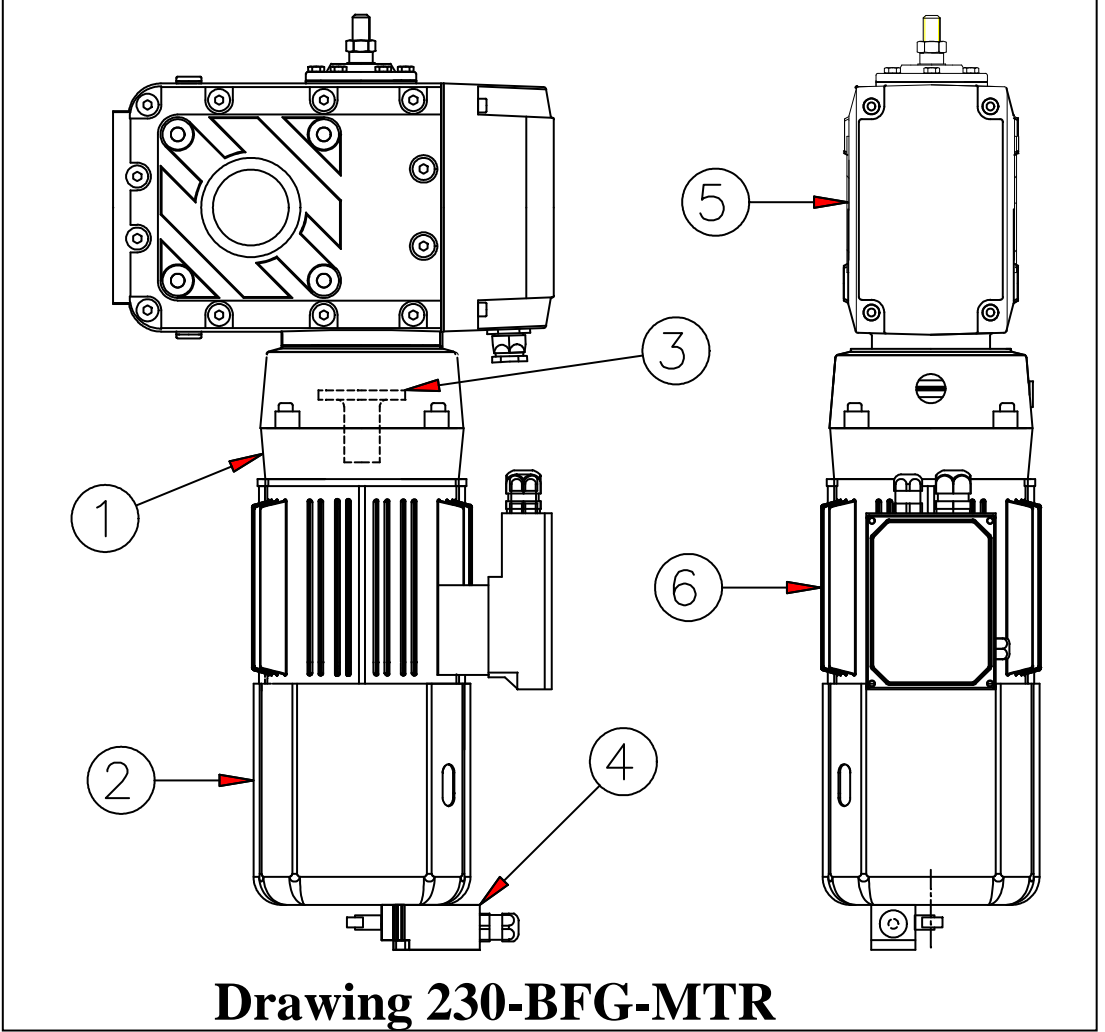

**Drawing 230-BFG-MTR**



<b>BONFIGLIOLI MOTOR w/ OVITOR GEARBOX</b>				
<i>Refer to Drawing and 230-BFG-MTR unless Noted</i>				
ITEM	ITEM DESCRIPTION	PART #	QTY	NOTE(S)
1	FLANGE, MOTOR ATTACHMENT, BONFIG. MOTOR TO OVITOR	6625T0001	1	
2	COVER, FAN, LARGE, BONFIG. MOTOR	6621T0002	1	
3	CLUTCH PLATE, MOTOR SIDE	6611T0002	1	
4	<u>CRANK SWITCH, ROTARY</u> BRACKET, CRANK SWITCH MNT	<u>4905T0003</u> 990061-4000	1	
5	GEARBOX, TVRC HOLLOW SHAFT, SZ 8	6610T0007	1	
6	MOTOR, BONFIGLIOLI, 1-SPEED 230 / 480VAC MOTOR, BONFIGLIOLI, 1-SPEED 600 VAC MOTOR, BONFIGLIOLI, 2-SPEED 230VAC MOTOR, BONFIGLIOLI, 2-SPEED 480VAC MOTOR, BONFIGLIOLI, 2-SPEED 600VAC	6620T0001 6620T0002 6620T0003 6620T0004 6620T0005	1	
<b>ADDITIONAL ITEMS SHOWN ON DRAWING 230-M032</b>				
1	CLUTCH PRESSURE PLATE, GB	00-1083-25	1	
2	FRICITION LINING	00-0481-25	1	

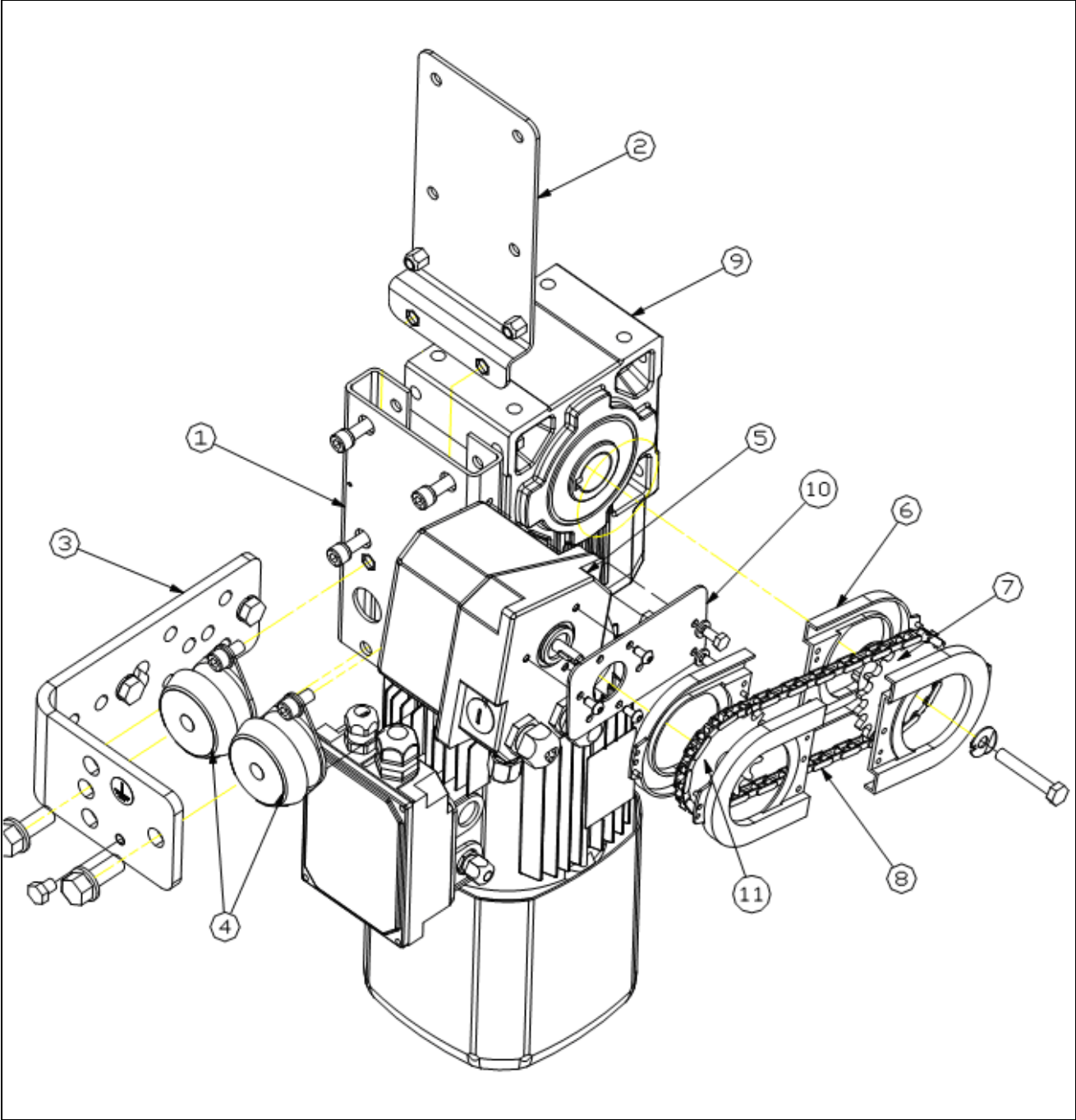

DRAWING # 230-M2006



**BONFIGLIOLI MOTOR & GEAR BOX**

*Refer to Drawing and 230-M2006 unless Noted*

ITEM	ITEM DESCRIPTION	PART #	QTY	NOTE(S)
1	BRACKET, MOTOR MTG.	4521R0034	1	
2	BRACKET, MOTOR MTG. REINFORCEMENT	4521R0036	1	
3	BRACKET, TORQUE ARM	4521R0776	1	
4	VIBRATION DAMPNER	5004R0041	2	
5	LIMIT SWITCH BOX, 4 SWITCH STROMAG	4906027	1	
6	GUARD, LIMIT SWITCH CHAIN	4906R0015	1	Comes as a set
7	SPROCKET, LIMIT SWITCH DRIVE 46C18ZI 9mm BORE	4521R0206	1	
8	CHAIN, 1/2 X 3/16 #40, 44 LINKS	5105R0036	1	
9	DRIVE UNIT, 1 SP 220/480V, 1.1KW, 18:6 DRIVE UNIT, 2SP 220V, 1.1KW, 18:6 DRIVE UNIT, 2SP 480V, 1.1KW, 18:6 DRIVE UNIT, 1SP 600V, 1.1KW, 18:6 DRIVE UNIT, 2SP 600V, 1.1KW, 18:6	6601T0028 6601T0025 6601T0026 6601T0029 6601T0027	1	
10	BRACKET, LIMIT SWITCH	4521R0775	1	
11	SPROCKET, LIMIT SWITCH BOX 46C18ZI 8MM BORE	4521R0448	1	
	SEE DRWG # 8410T0001-23BRK ON PRIOR PAGES FOR ADDITIONAL DRIVE PARTS			

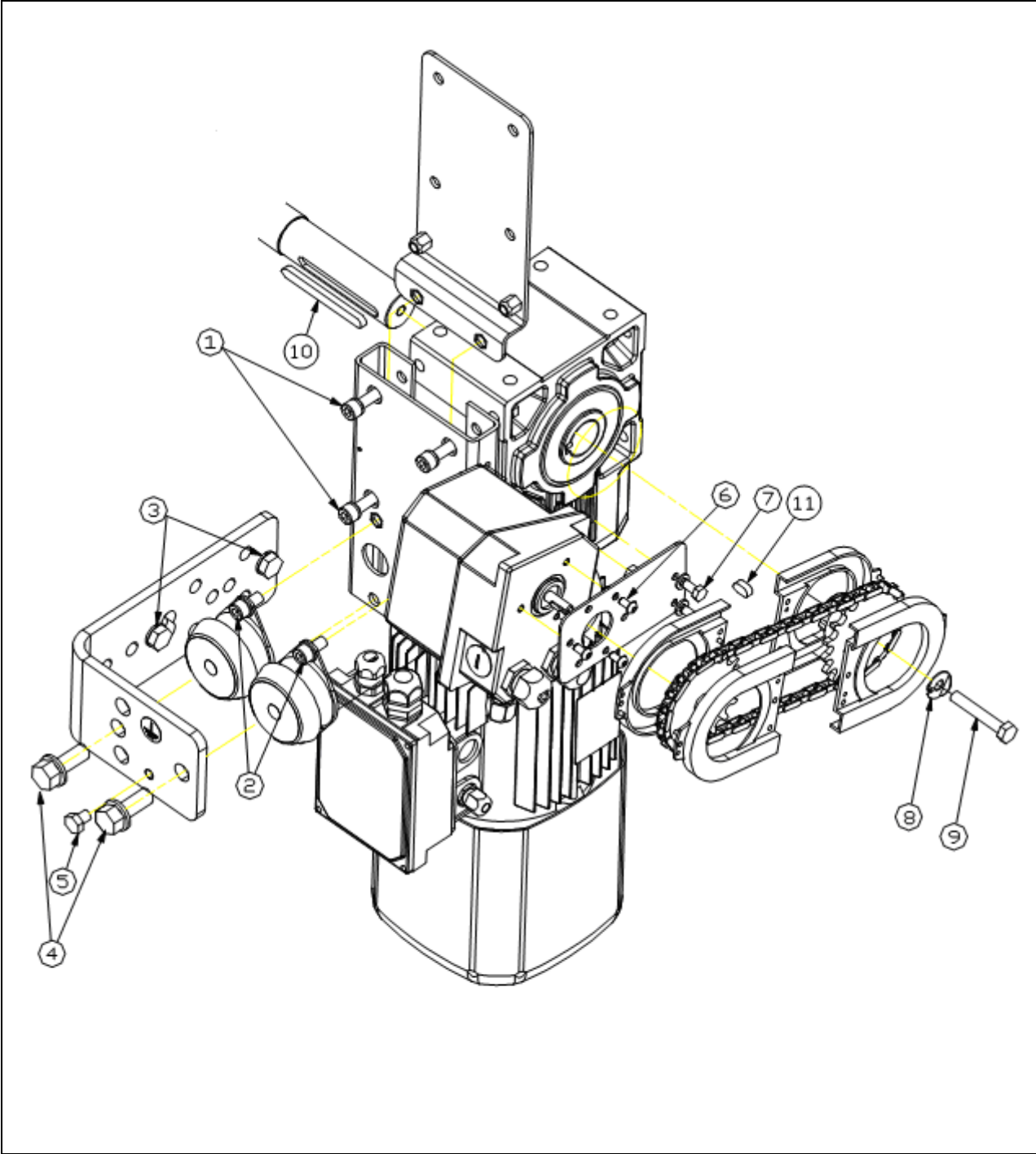

DRAWING # 230-M2006 HARDWARE



<b>BONFIGLIOLI MOTOR &amp; GEAR BOX</b>				
<i>Refer to Drawing and 230-M2006 HARDWARE unless noted</i>				
ITEM	ITEM DESCRIPTION	PART #	QTY	NOTE(S)
1	<u>WASHER, LOCK M8</u> <u>WASHER, FLAT M8</u> <u>BOLT, M8 x 25 SHCS</u> NUT, M8		4	
2	<u>NUT, M8</u> BOLT, M8 x 16 SHCS		4	
3	BOTL, HHCS M10 x 30		2	
4	BOLT, HHCS M12 x 50		2	
5	BOLT, HHCS M8 x 10		1	
6	BOLT, BHCS M5 x 10		3	
7	<u>NUT, M6</u> <u>BOLT, HHCS M6 x 12</u> WASHER, FLAT M6		2	
8	WASHER, TABBED M8		1	
9	BOLT, HHCS M8 x 50		1	
10	KEY, M8 X 7 X 70, DRIVE SHAFT		1	
11	KEY, M8 x 7 x 12, LIMIT BOX SHAFT		1	

SIDE FRAME ASSEMBLY – OLD STYLE

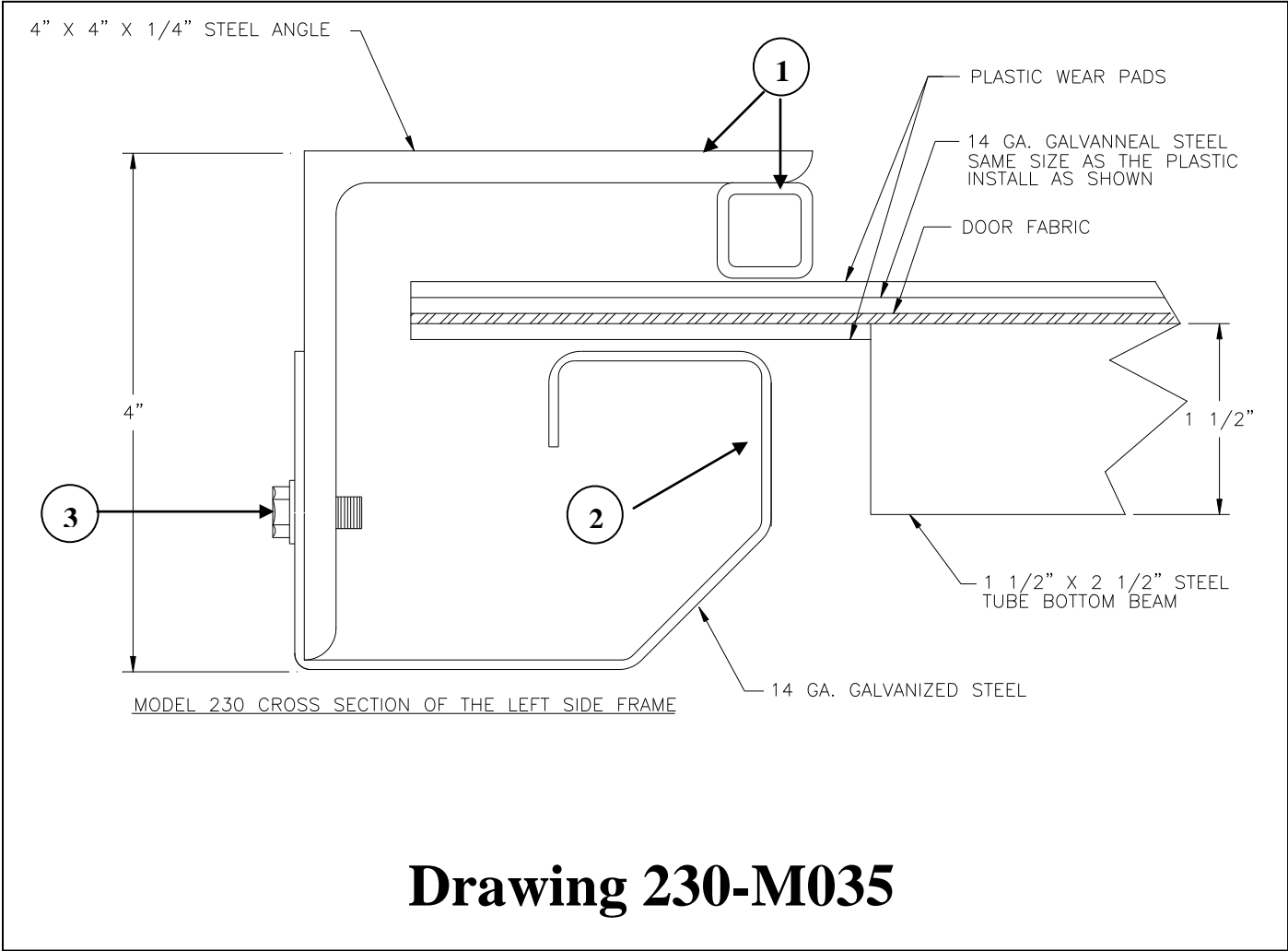



**230 SIDE FRAME ASSEMBLY / OLD STYLE**

*Refer to Drawing 230-M035 unless Noted*

<b>ITEM</b>	<b>ITEM DESCRIPTION</b>	<b>PART #</b>	<b>QTY</b>	<b>NOTE(S)</b>
1	SIDE FRAME ASSY – MODEL 230, CONSISTING OF:	SEE BELOW	2	
	ANGLE, STEEL	23-4980-96	Per ft	DH + 17"
	TUBE, SQUARE .75 X .75	23-4220-96	Per ft	DH + 17"
2	SIDE FRAME COVER	23-4992-96	2	DH + 3"
3	3/8-16 X 1/2" FLANGED HEX HD BOLT	N/A	6	

**NOTE**

**PRIOR TO PLACING ANY ORDERS, PLEASE CONFIRM PARTS ABOVE WITH DOOR SERIAL NUMBER. SOME PARTS HAVE BEEN CHANGED. PLEASE STATE THE HANDING REQUIRED.**

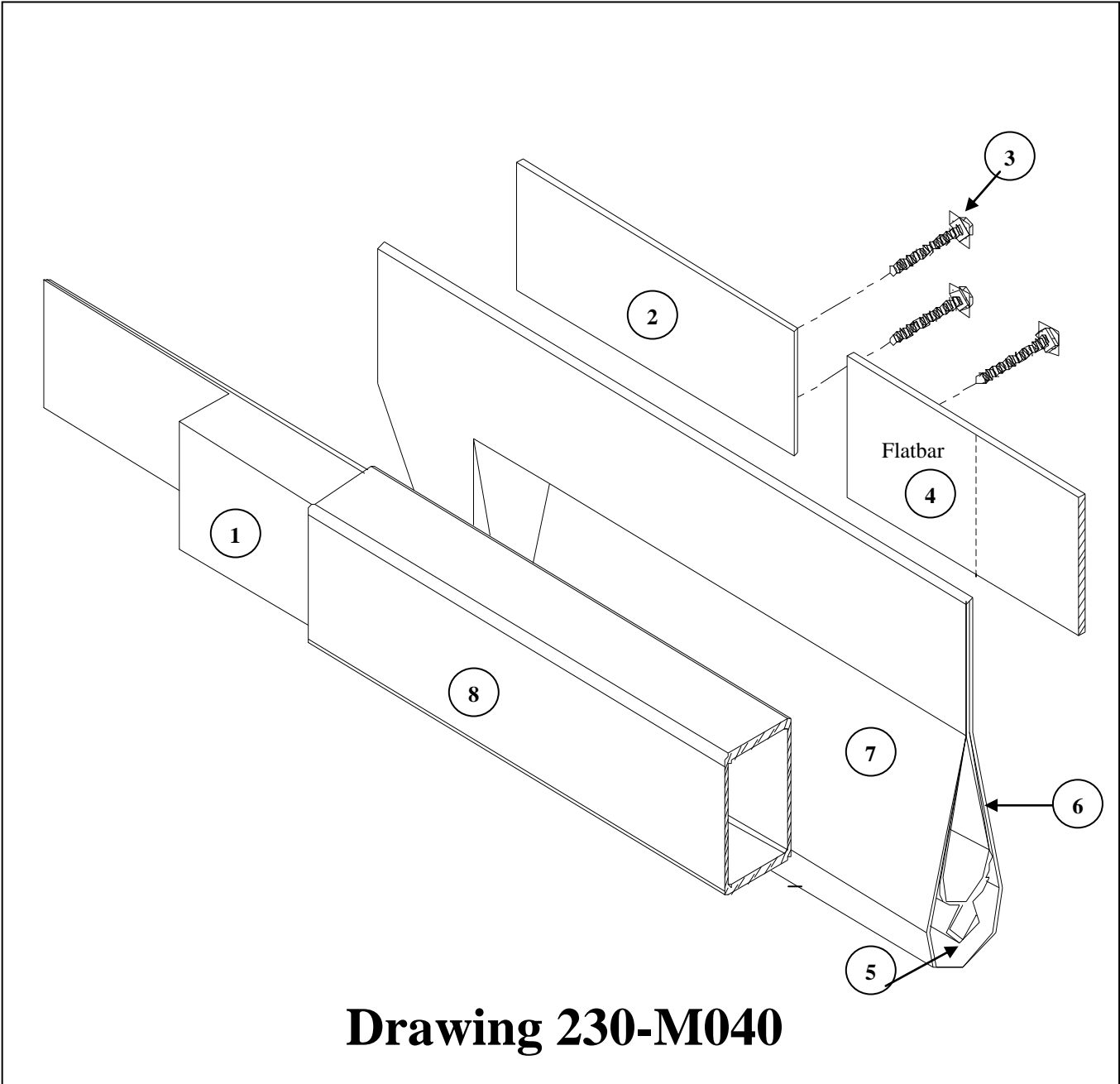



**230 BOTTOM BEAM ASSEMBLY / OLD STYLE**

*Refer to Drawing 230-M040 and 230-M045 unless Noted*

<i>ITEM</i>	<i>ITEM DESCRIPTION</i>	<i>PART #</i>	<i>QTY</i>	<i>NOTE(S)</i>
1	END BRACKET 2.25 X 1.25 X 8 UHMW	23-1505-96	2	
2	END BRACKET GUIDE 2.25 X 1/8 X 6	23-1504-96	2	
3	TEK SCREW, 10-24 X 1.5"	NO PART #	A/R	
4	FLAT BAR	23-1500-96	Per ft	DW - 6"
5	MESH FABRIC	N/A	1	DW - 4"
6	RUBBER PROFILE	10-1230-88	Per ft	DW - 4"
	RUBBER ENDPiece PLUG	K310-0021	2	Not Shown.
	SAFETY EDGE PLASTIC TUBE	96-1308-83	2'	Not Shown
7	<u>YELLOW SAFETY EDGE FABRIC 15"</u> SPECIAL FABRIC 30" SPECIAL	<u>96-1412-91</u> 998155-4000	Per ft	DW + 6"
8	RECT TUBE, STEEL	23-1501-96	Per ft	DW - 2"
	Misc Information:			
A	COMPLETE BOTTOM BEAM ASSEMBLY	K23-1010-16		Items C & D below not included
<p><b>When ordering the complete Bottom Beam Assembly, please include Door Serial Number. If not available, provide actual Rapid Roll Opening (between side frames), and drive side location</b></p>				
<i>ADDITIONAL ITEMS NOT SHOWN</i>				
B	Bircher Pressure Switch w/Enclosure	96-6000-79	1	
C	Retractable Cable, 4' 18/2C SVO-300V, 2-Wire	96-6100-83	1	

CHAIN DRIVE ASSEMBLY

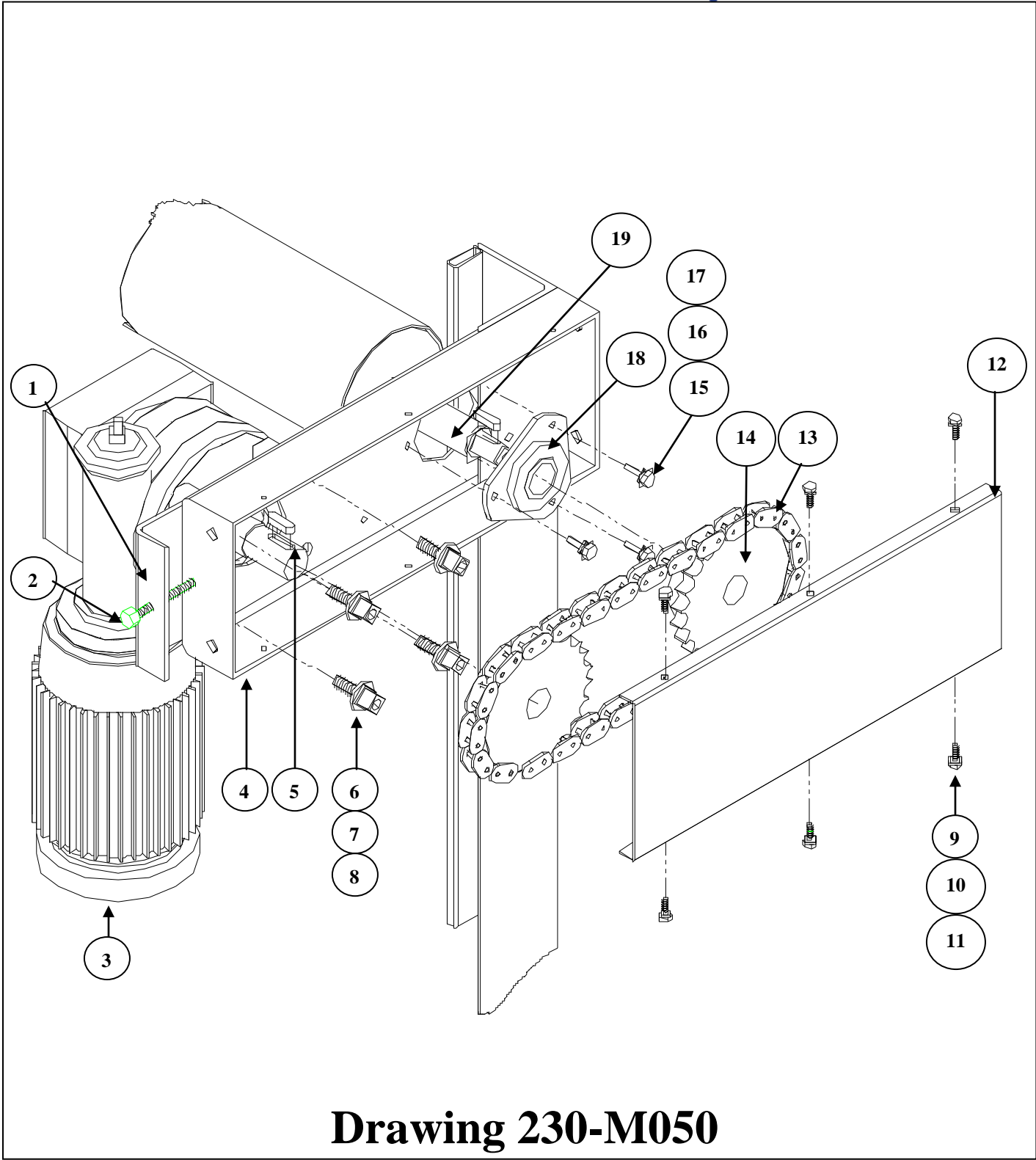

**Drawing 230-M050**

## **230 OVITOR ONLY, CHAIN DRIVE ASSEMBLY**

*Refer to Drawing 230-M050 unless Noted*

<b>ITEM</b>	<b>ITEM DESCRIPTION</b>	<b>PART #</b>	<b>QTY</b>	<b>NOTE(S)</b>
1	CHAIN DRIVE BRKT, SIZE 8	23-9213-97	1	INCL TENSIONER & COVER
2	TENSION ADJUSTMENT BOLT	NPN	1	BOLT, 3/8-16 X 2 1/2" LG
3	DOOR MOTOR		1	Refer to dwrg # 230-M015
4	PART OF ITEM 1 ABOVE.			
5	GEARBOX KEY	NPN	1	INCLUDED W/SPROCKET
6	BOLT, HEX HD M10 X 30MM	NPN	4	
7	WASHER, LOCK - M10	NPN	4	
8	WASHER, FLAT - M10	NPN	4	
9	CHAIN COVER SELF TAPPING SCREW	NPN	6	
10	N/A			
11	N/A			
12	PART OF ITEM 1 ABOVE.			
13	CHAIN 60 FOR SZ 8	67-9211-01	1	36" LONG
14	CHAIN WHEEL SPRKT, 60B17, 1" BORE	23-9211-04	1	INCL KEY
	CHAIN WHEEL SPRKT, 60B17, 32MM BORE	67-9211-04	1	INCL KEY, GEARBOX SD
15	BOLT, HEX HD 5/16-18 X 3/4"	NPN	6	BEARING FLANGE
16	WASHER, LOCK 5/16"	NPN	6	
17	WASHER, FLAT 1/4"	NPN	6	
18	BEARING PLATE	23-4905-96	2	
	BEARING W/COLLAR	23-4713-96	2	
	BEARING FLANGE RING	23-4714-96	4	
19	ENDBOSS, STUBAXLE CHAINDRIVE	23-3661-97	1	

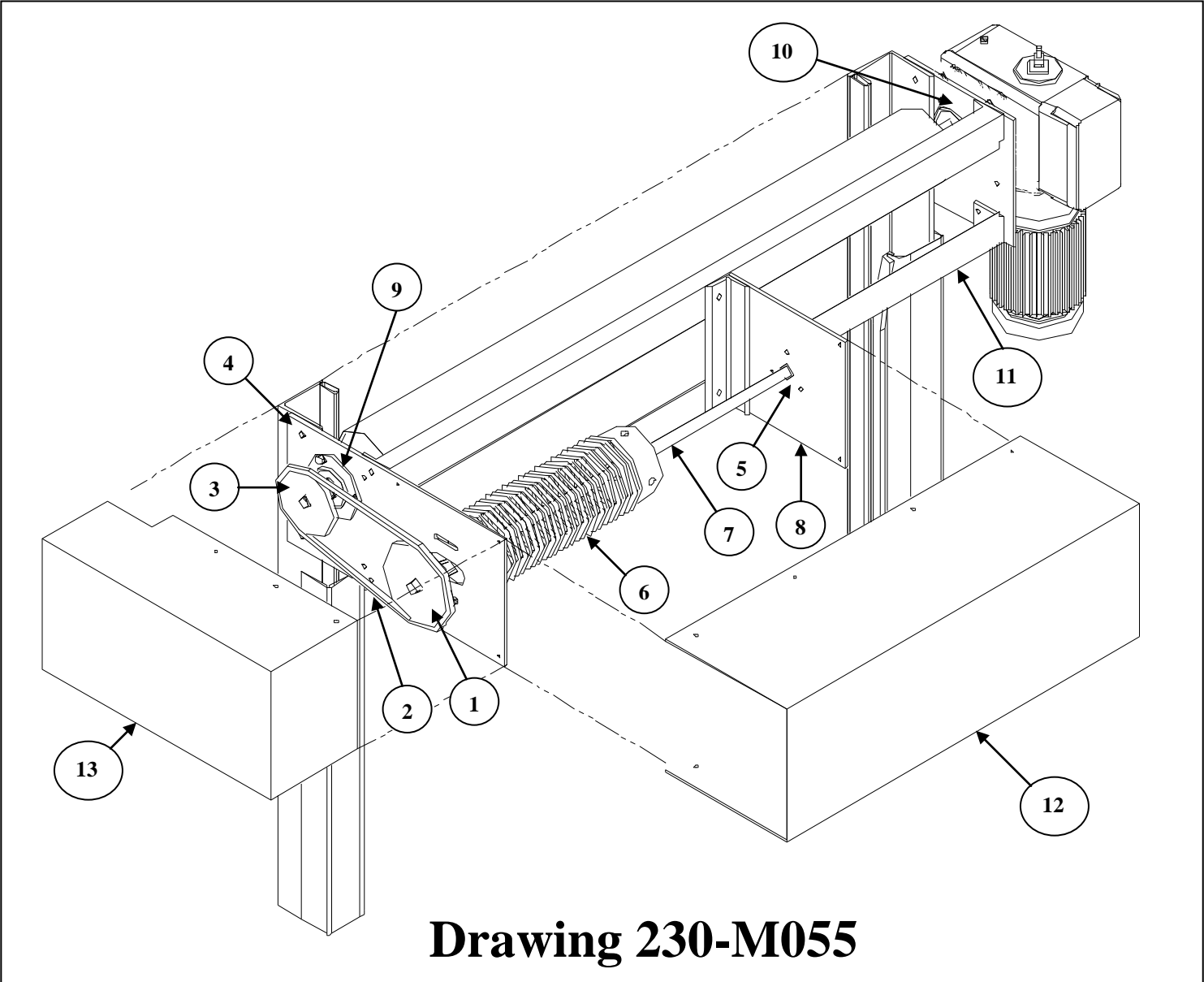

**Drawing 230-M055**



**230 TOP ROLL, CSS ASSEMBLY**

*Refer to Drawing 230-M055 unless Noted*

<b>ITEM</b>	<b>ITEM DESCRIPTION</b>	<b>PART #</b>	<b>QTY</b>	<b>NOTE(S)</b>
1	SPROCKET, 50B31	23-9217-99	1	
2	CHAIN, #50	23-9218-99	1	
3	SPROCKET, 50B24	23-9216-99	1	
4	PLATE, SPRING BEARING	23-9229-99	1	
5	BEARING 1"	18-0610-97	1	
6	SPRING, GENERIC 230 CSS	23-9231-99	1	SPECIFY DOOR SERIAL NUMBER.
7	SHAFT 1" KEYED	18-0608-97	1	
8	PLATE, MIDDLE SPRING	23-9226-99	1	
9	BEARING, 1" W/COLLAR	28-4970-94	1	
10	PLATE, BEARING - DRIVESIDE, 230	23-9230-99	1	
11	SPREADER BAR	18-0151-97	2	W+7.5" (Weld on end Plates)
12	COVER, SPRING - 230	23-1020-99	1	
13	CHAIN GUARD, 230	23-1021-99	1	
<b>ITEMS NOT SHOWN ON DWG 230-M055 ASSEMBLY</b>				
	BOLT, 1/2"-13 X 1.5 HEX HD		6	
	NUT, HEX 1/2" -13		6	
	WASHER, LOCK 1/2"		6	
	WASHER, FLAT, 1/2"		12	
	NUT, HEX 3/8"-16		6	

COUNTER BALANCE ASSEMBLY



	WASHER, LOCK 3/8"		6	
	WASHER, FLAT, 3/8"		6	

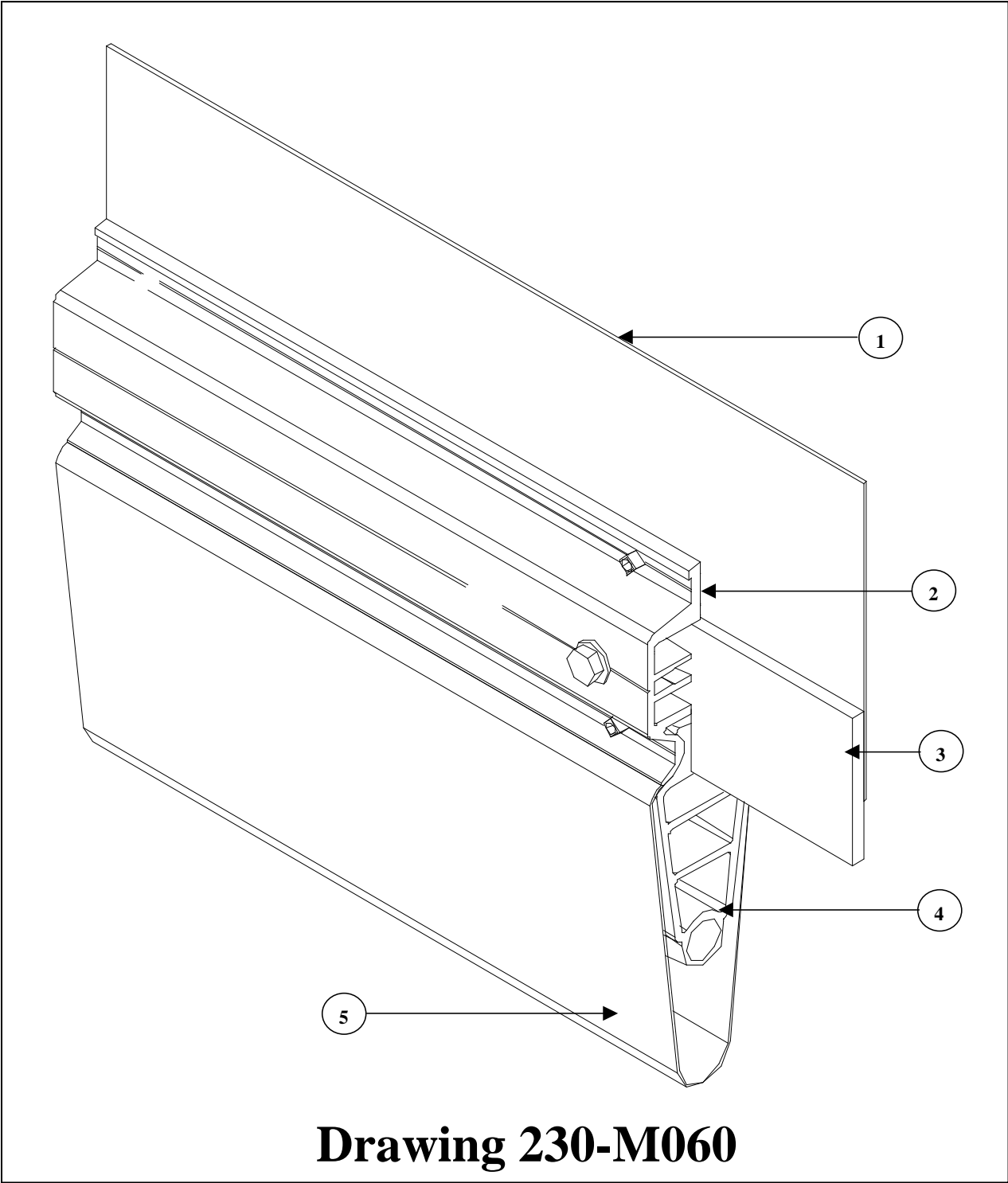

**Drawing 230-M060**



**230 BOTTOM BEAM ASSEMBLY/NEW DESIGN**

*Refer to Drawing 230-M060 unless Noted*

<b>ITEM</b>	<b>ITEM DESCRIPTION</b>	<b>PART #</b>	<b>QTY</b>	<b>NOTE(S)</b>
1	DOOR FABRIC			Contact factory w/ door serial number
2	BOTTOM BEAM ALUMINUM, H=3.25"	23-1100-00	2	Door width – 1.5"
3	ENDBRACKET, UHMW	23-1505-00	4	
4	RUBBER PROFILE	705405	1	W - 1.75"
5	SAFETY EDGE YELLOW FABRIC	96-1412-00	1	W + 6"
<b>A</b>	COMPLETE BOTTOM BEAM ASSY	K23-1020-16		Does not include items B & C below
<p><b>When ordering the complete Bottom Beam Assembly, please include Door Serial Number. If not available, provide actual Rapid Roll Opening (between side frames), and drive unit side location.</b></p>				
<p><b><u>THE COMPLETE BOTTOM BEAM ASSY</u></b> <b><u>DOES NOT INCLUDE THE PRESSURE SWITCH AND RETRACTILE CABLE</u></b></p>				
<b>B</b>	PRESSURE SWITCH	96-6000-79	1	
<b>C</b>	RETRACTILE CABLE	96-6100-83	1	
<b>D</b>	PNEUMATIC EDGE REPAIR KIT	K310-0021	1	Comes w/ plugs, glue & clear tube w/ fitting

SIDE FRAME ASSEMBLY – NEW STYLE

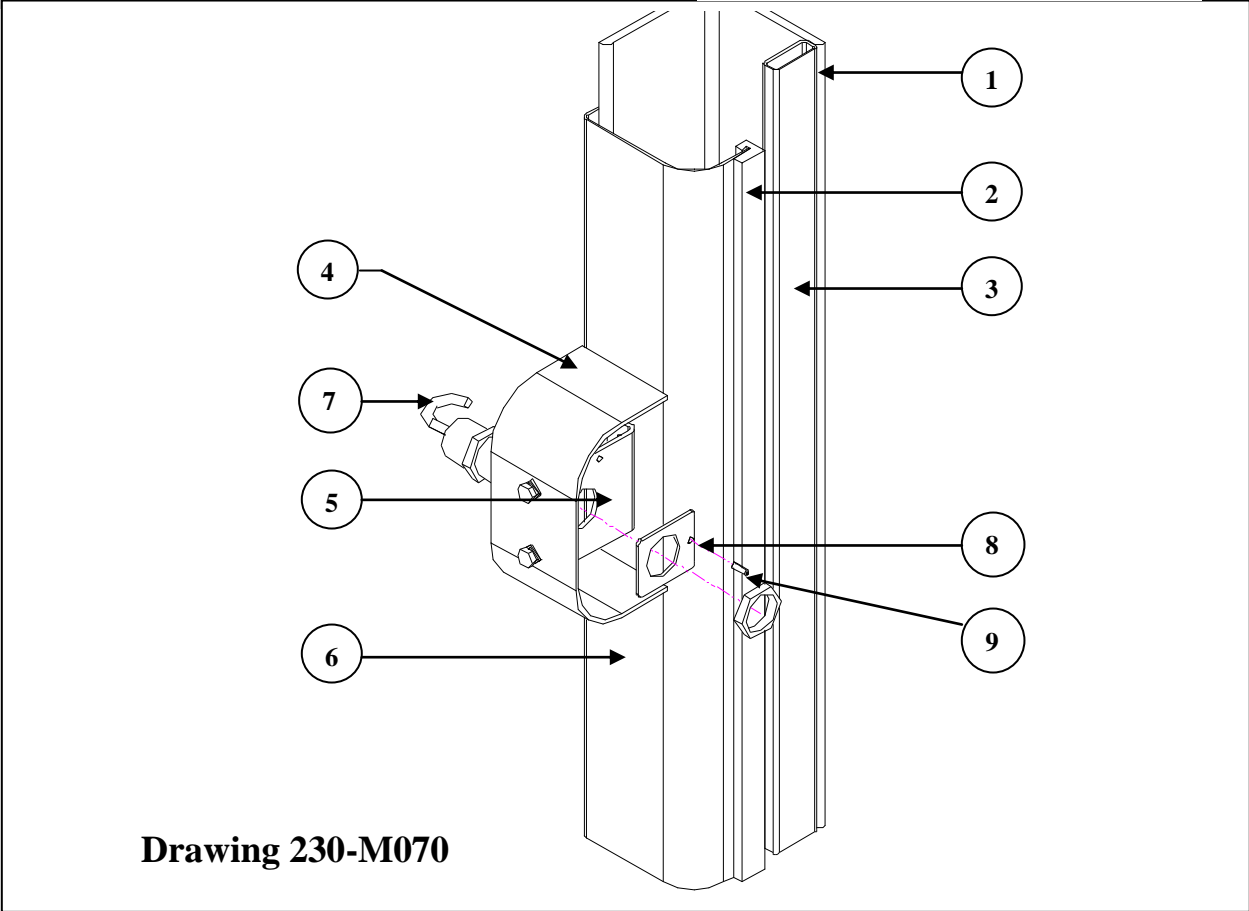
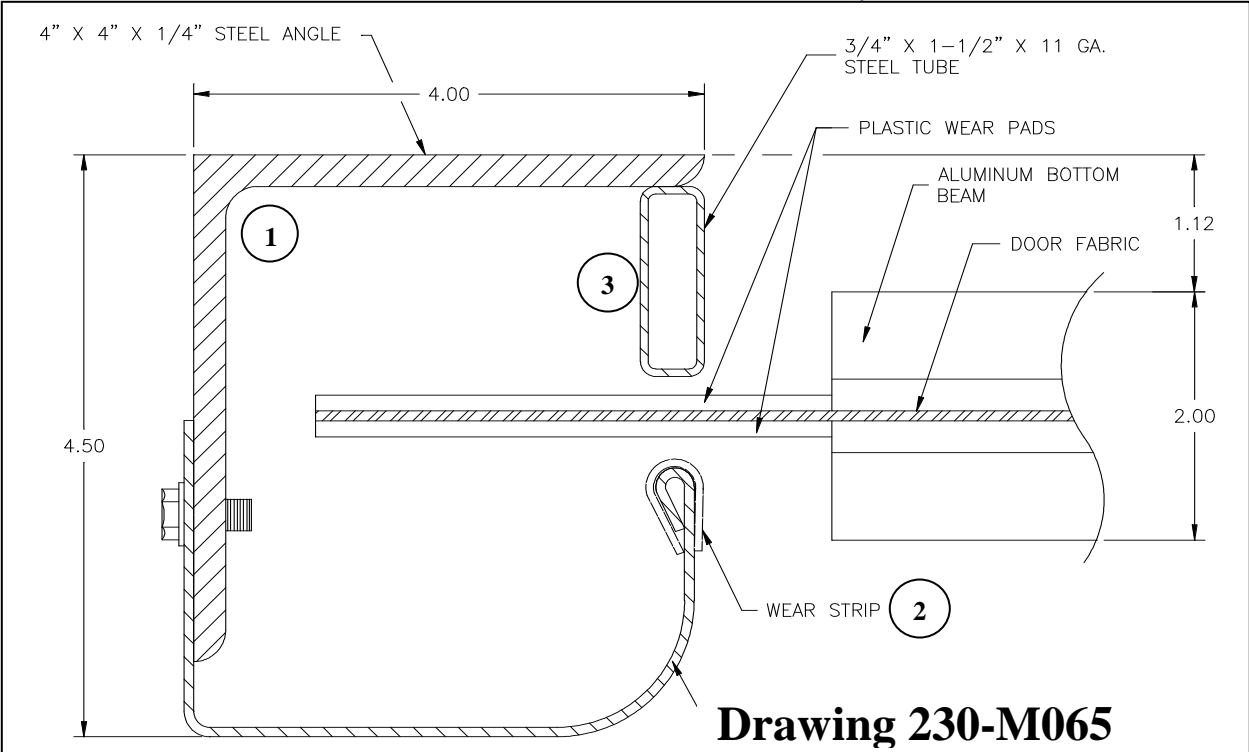



**230 SIDE FRAME ASSEMBLY, NEW STYLE**

*Refer to Drawing 230-M065 and 230-M070 unless Noted*

<b>ITEM</b>	<b>ITEM DESCRIPTION</b>	<b>PART #</b>	<b>QTY</b>	<b>NOTE(S)</b>
1	STEEL ANGLE, SIDE FRAME MDL 230	23-4980-96	2	DH + 17"
2	WEAR STRIP, MDS FILLED NYLON	23-4999-00	2	DH + 17"
3	RECTANGLE TUBING, 1.5 X 1.0 X 16 GA, MDL 230	23-4220-00	2	DH + 17"
4	PHOTOCELL GUARD, MDL 230	23-8003-00	2	
5	BRACKET, REFLECTIVE, MDL 230	23-8002-00	2	
	BRACKET, THRU BEAM	23-8001-00	2	
6	COVER, SIDE FRAME 156" (230 W/HEM)	23-4997-00	2	DH + 2"
	COVER, SIDE FRAME 192" (230 W/HEM)	23-4998-00	2	DH + 2"
7	PHOTOCELL, REFLECTIVE ( Banner )	87-6360-30	1	See next page for new ADS style
	PHOTOCELL, THRU BEAM ( Banner )	87-6360-10	1	See next page for new ADS style
8	ADJUSTMENT BRACKET, REFLECTIVE	23-5001-00	1	
	ADJUSTMENT BRACKET, THRU BEAM	23-5000-00	1	OLD NPN STYLE
9	SET SCREW, 10-32 X 1/2"	NPN	1	

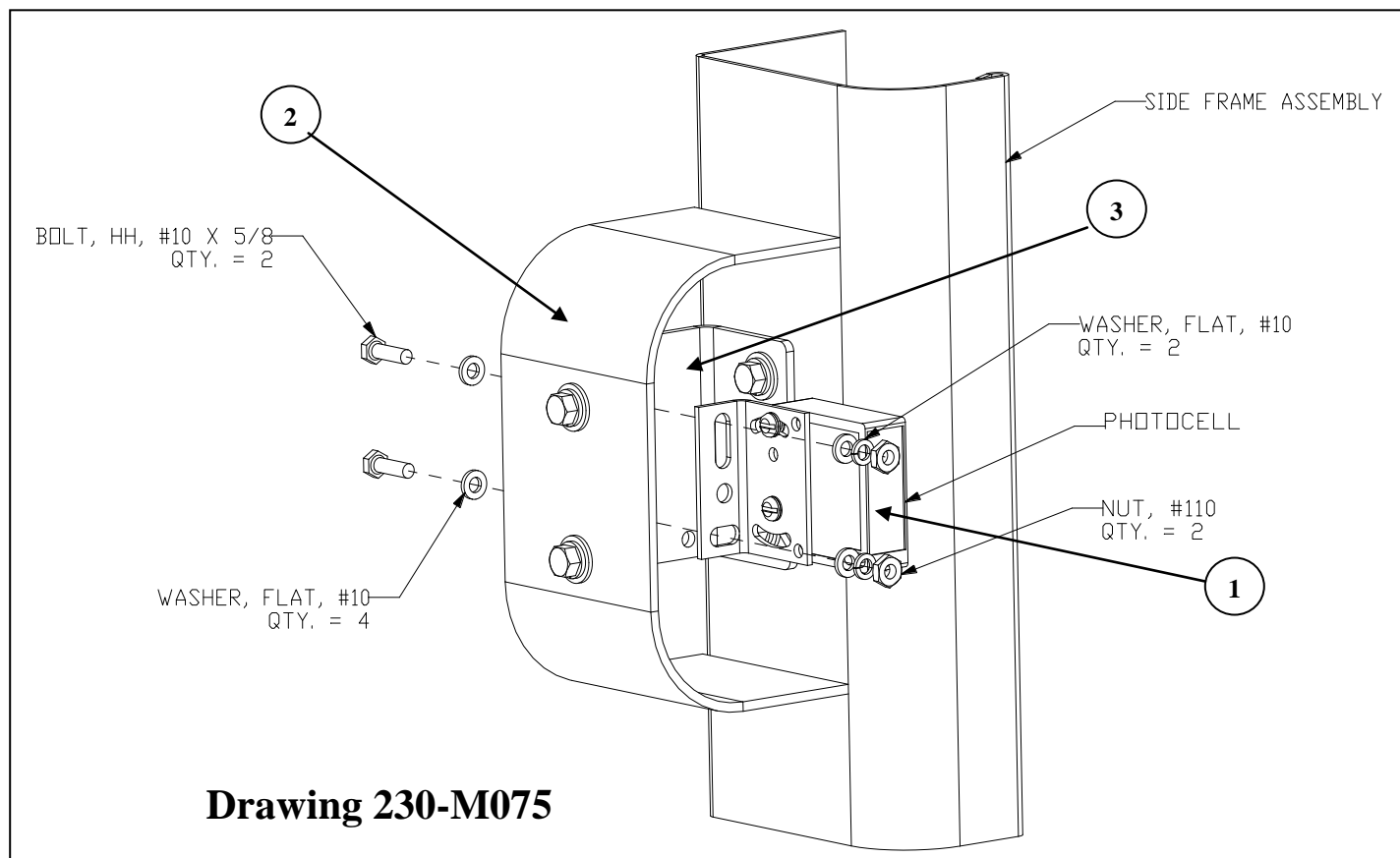

**230 NEW STYLE PHOTOCELLS (ADS)**

*Refer to Drawing 230-M075 unless Noted*

<b>ITEM</b>	<b>ITEM DESCRIPTION</b>	<b>PART #</b>	<b>QTY</b>	<b>NOTE(S)</b>
1	PHOTOCELL, ADS, EMITTER & RECEIVER	8904R0002	1	
	PHOTOCELL, ADS, REFLECTIVE	4904R0001		REQUIRES REFLECTOR
	REFLECTOR, ADS	4904R0008		
2	PHOTOCELL GUARD, MDL 230	23-8003-00		
3	BRACKET, PHOTOCELL, ADS	230031-4000		

FRONT COVER

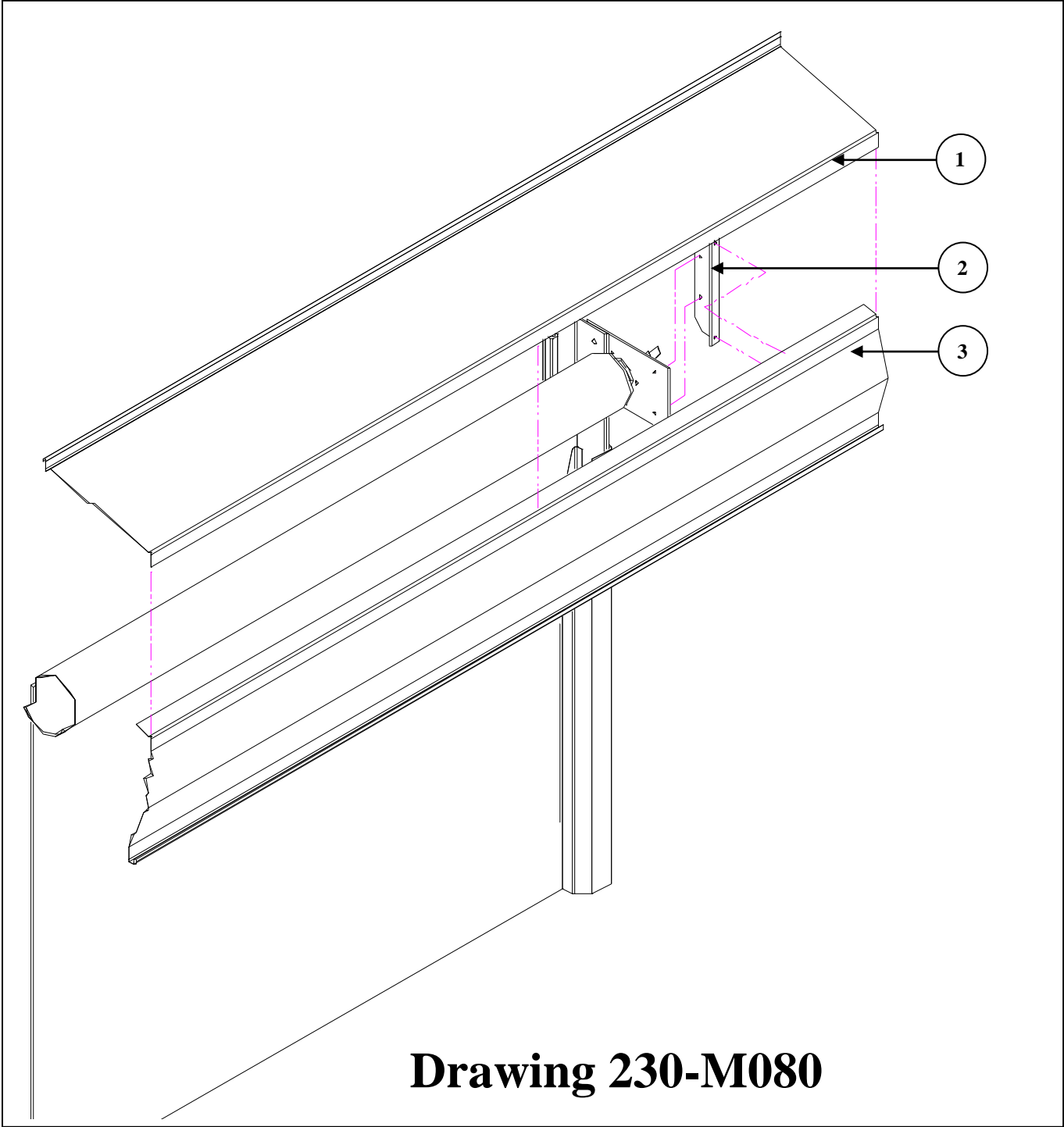

**Drawing 230-M080**

# FRONT COVER

## **230 FULL ROLL COVER ASSEMBLY**

*Refer to Drawing 230-M080 unless Noted*

<b>ITEM</b>	<b>ITEM DESCRIPTION</b>	<b>PART #</b>	<b>QTY</b>	<b>NOTE(S)</b>
1	FULL ROLL COVER TOP (163" LG)	67-4990-00	1	DW + 23"
	FULL ROLL COVER TOP (211" LG)	67-4991-00	1	DW + 23"
2	BRACKET, 230 COVER	23-4985-98	2	
3	FRONT COVER (163"LG)	67-4995-00	1	
	FRONT COVER (211"LG)	67-4996-00	1	
	BOLT, 5/16 - 18 X 1" HEX HD		4	NOT SHOWN ON DWG
	WASHER, FLAT 5/16"		4	NOT SHOWN ON DWG
	WASHER, LOCK 5/16"		4	NOT SHOWN ON DWG
	BOLT, 1/4 - 20 X 3/4" HEX HD		4	NOT SHOWN ON DWG
	NUT, 1/4 - 20, NYLOCK HEX		4	NOT SHOWN ON DWG
	WASHER, FLAT 1/4"		8	NOT SHOWN ON DWG
	FULL ROLL COVER ENDCAP, 230, LH	23-4987-00	1	NOT SHOWN ON DWG
	FULL ROLL COVER ENDCAP, 230, RH	23-4988-00	1	NOT SHOWN ON DWG
**	Cover, Full Roll Assembly, Model 230	K23-1030-12		contains all items above
<b>THE FOLLOWING PARTS (NOT SHOWN, SEE APPROVAL DRAWING FOR DETAIL 230-0010)                      LIST IS FOR THE MOTOR COVER OPTION.  <u>THIS CAN ONLY BE USED WITH FULL ROLL COVER</u></b>				
	MOTOR COVER, LARGE	67-4985-91	1	For Bonfig or Leroy Somers motors
	MOTOR COVER, STANDARD	67-4986-93	1	For use w/ Ovtior motor only
	JAMB BRACKET	18-0106-97	1	Required to mount the bottom of the motor cover
	BOLT, 5/16-18 X 1" LG HEX HD		4	
	WASHER, FLAT 5/16"		4	
	WASHER, LOCK 5/16"		4	

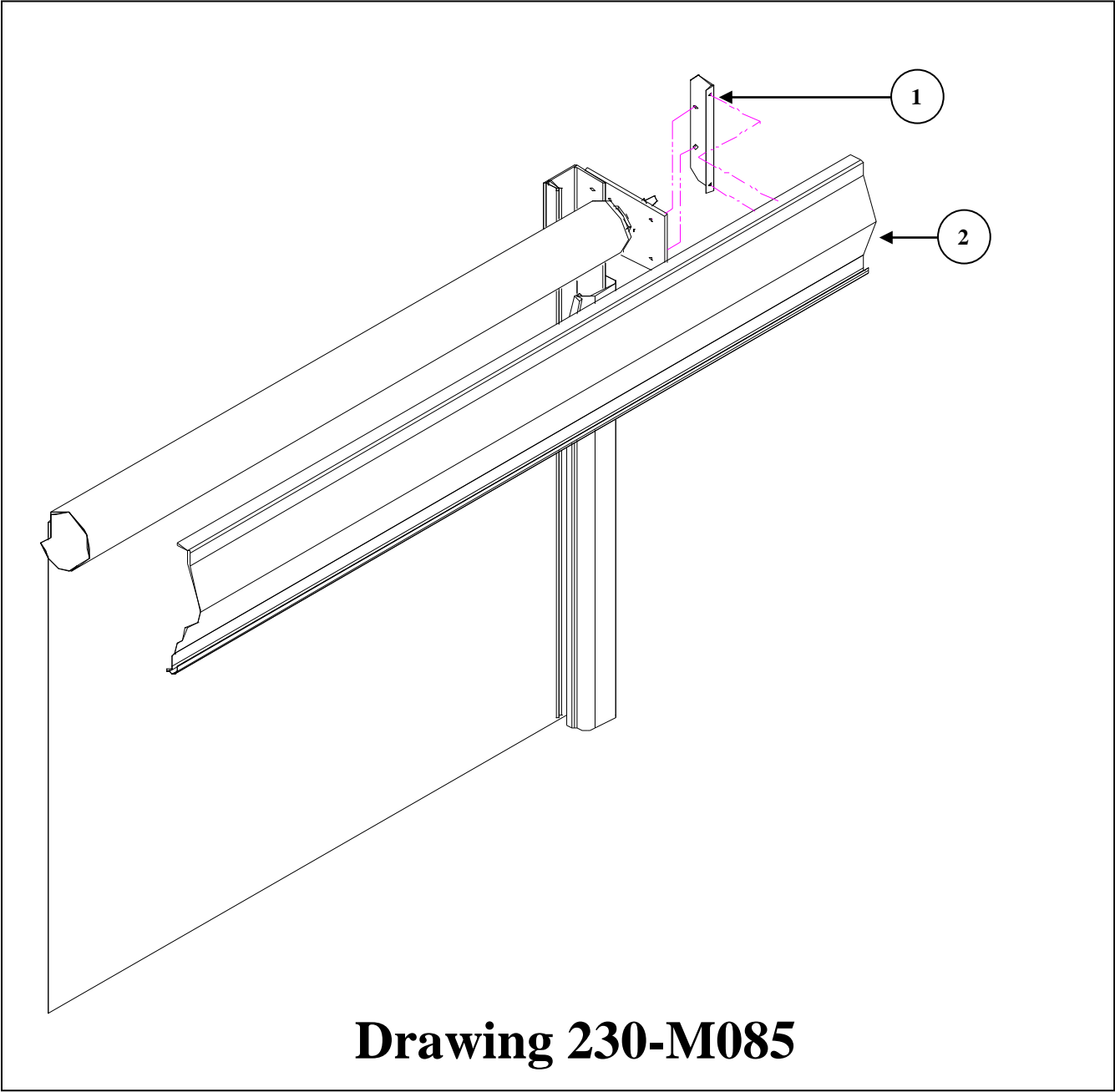

**Drawing 230-M085**

# FRONT COVER

---

<b>230 FRONT COVER ASSEMBLY</b>				
<i>Refer to Drawing 230-M085 unless Noted</i>				
<b>ITEM</b>	<b>ITEM DESCRIPTION</b>	<b>PART #</b>	<b>QTY</b>	<b>NOTE(S)</b>
1	BRACKET, 230 COVER	23-4985-98	2	
2	FRONT COVER (163" LG)	67-4995-00	1	W + 23"
	FRONT COVER (211" LG)	67-4996-00	1	
	BOLT, 5/16-18 X 1" HEX HD		4	
	WASHER, FLAT 5/16"		4	
	WASHER, LOCK 5/16"		4	
	BOLT, 1/4-20 X 3/4" HEX HD		4	
	NUT, 1/4-20, NYLOCK HEX		4	
	WASHER, FLAT 1/4"		8	
**	Cover, Front Assembly, Model 230	K23-1035-12		include all items above